

Oil Service Unit**Compact Filter Pack CFP 03**

Ultra-light and compact · Multi-purpose system · Ergonomic design · Simplifies servicing of small power packs



Oil Service Unit CFP



Suction-return Adapter

- › Exclusive solution for small tanks
- › Perfect device for maintenance services
- › Weight only 7.8 kg / 17.3 lbs
- › Filter elements EXAPOR®MAX 2
- › Electric motor with switch
- › Smart suction-return adapter

Description**Maintenance of small power packs**

The CFP is a multi-purpose off-line filter unit, designed for servicing small power packs on a daily basis, not only to be used during start-up or a breakdown.

Thanks to its characteristics, the CFP fills the gap in the market as a first unit designed not only for filling but also for cleaning of hydraulic systems.

Ideal service equipment

The compact size and low weight make the device easily transportable from machine to machine without needing any extra transport aids.

The CFP can be used in systems where other devices are not applicable: in machines with difficult access to the oil tank or when working at height.

Dirt-holding capacity

The dirt-holding capacity values in grams from the ISO MTD test dust are in accordance with the ISO 16889 requirements.

Multi-purpose system

The CFP unit can be used for transferring oils, filling of systems with filtered oil or for off-line filtration. Off-line filtration is possible even in systems where only one connection port is available. The special suction-return adapter allows both the suction and the pressure hose to be connected to the tank (for example via the ventilating filter port).

Application examples

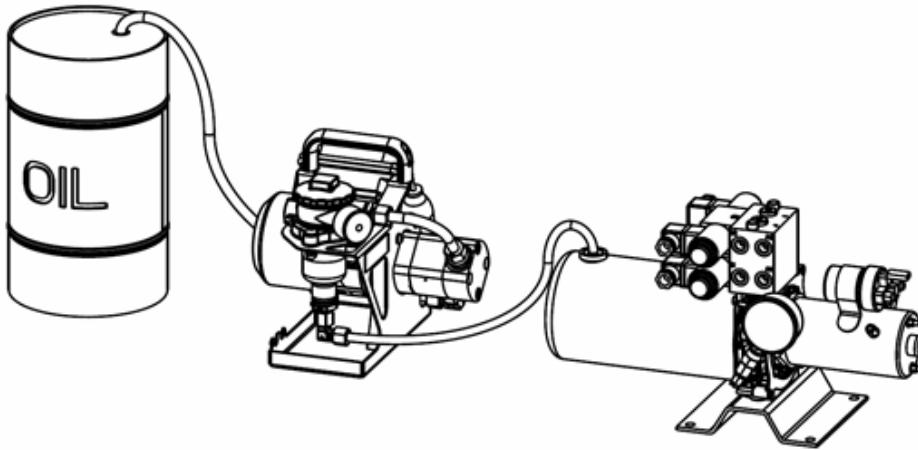

Application example 1:
Oil transfer, filling of the small power pack with fresh oil.

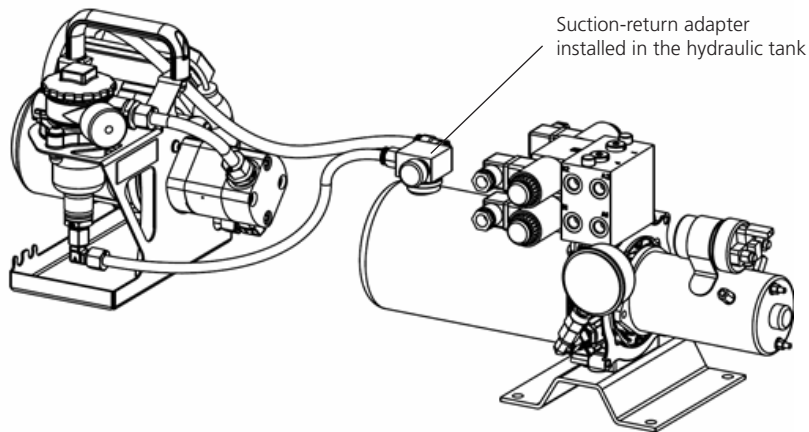

Application example 2:
Service of hydraulic systems. Off-line filtration at small power packs with only one available connection port.
Suction-return adapter installed in the ventilating filter port.

Characteristics

Hydraulic connection

Hoses:

Suction hose DN12, length 2 m / 6.6 ft
Pressure hose DN8, length 2 m / 6.6 ft
Free end of hoses closed by protective caps

Electrical connection

Electric motor, air cooled fan with ON/OFF switch

Cable: length 2.5 m / 8.2 ft
Voltages: 1 ~ 230 V AC / 50/60 Hz
1 ~ 110 V AC / 50/60 Hz
Protection class: IP 54

Pump design

External gear pump with suction strainer installed in the suction port

Operating and transport position

Upright

Hydraulic fluids

Mineral oil and biodegradable fluids
Motor oils (see info sheet 00.20)
Other fluids on request

Temperature range of fluids

0 °C ... +60 °C / +32 °F ... +140 °F

Ambient temperature range

0 °C ... +50 °C / +32 °F ... +122 °F

Viscosity range

10 - 300 mm²/s - continuous operation without adapter
10 - 170 mm²/s - continuous operation with adapter

Selection Chart

	Order No. CFP 03-13	Order No. CFP 03-16	Order No. CFP 03-18	Order No. CFP 03-131
Nominal flow rate at v = 35 mm ² /s / 162 SUS	3 l/min* / 0.79 gpm*	3 l/min* / 0.79 gpm*	3 l/min* / 0.79 gpm*	3 l/min* / 0.79 gpm*
Filter fineness (Bx(c) = 200 according to ISO 16889:1999)	5 µm	10 µm	16 µm	5 µm
Dirt holding capacity	15 g	15 g	11 g	15 g
E-Motor operating voltage	1 ~ 230 V AC	1 ~ 230 V AC	1 ~ 230 V AC	1 ~ 110 V AC
E-Motor operating frequency	50/60 Hz	50/60 Hz	50/60 Hz	50/60 Hz
E-Motor power	0.06 kW*	0.06 kW*	0.06 kW	0.06 kW*
Electric plug	Type E/F	Type E/F	Type E/F	NEMA 5-15 (type B)
Length of suction hose	2 m / 6.6 ft	2 m / 6.6 ft	2 m / 6.6 ft	2 m / 6.6 ft
Length of pressure hose	2 m / 6.6 ft	2 m / 6.6 ft	2 m / 6.6 ft	2 m / 6.6 ft
Suction height max.	2.5 m / 8.2 ft	2.5 m / 8.2 ft	2.5 m / 8.2 ft	2.5 m / 8.2 ft
Operating pressure max.	3.5 bar / 50.8 psi	3.5 bar / 50.8 psi	3.5 bar / 50.8 psi	3.5 bar / 50.8 psi
Hydraulic symbol	1	1	1	1
Replacement element Order no.	V3.0510-53	V3.0510-56	V3.0510-58	V3.0510-53
Cracking pressure of by-pass	2.5 bar / 36.3 psi	2.5 bar / 36.3 psi	2.5 bar / 36.3 psi	2.5 bar / 36.3 psi
Clogging indicator	Manometer	Manometer	Manometer	Manometer
Weight	7.8 kg / 17.3 lbs	7.8 kg / 17.3 lbs	7.8 kg / 17.3 lbs	7.8 kg / 17.3 lbs

* Indications at 50 Hz. At 60 Hz the value increases by approx. 20 %.

Accessories:

- › Suction-return adapter CFP-A-09/05

On request:

- › Customized versions
- › Other electric plugs
- › Hose extensions
- › Filter elements with other finenesses
- › Adapter with other length of suction and return hose
- › Connecting fitting G½", M22 x 1.5 (or other customized threads) for installation of the suction-return adapter in plastic tanks

Dimensions

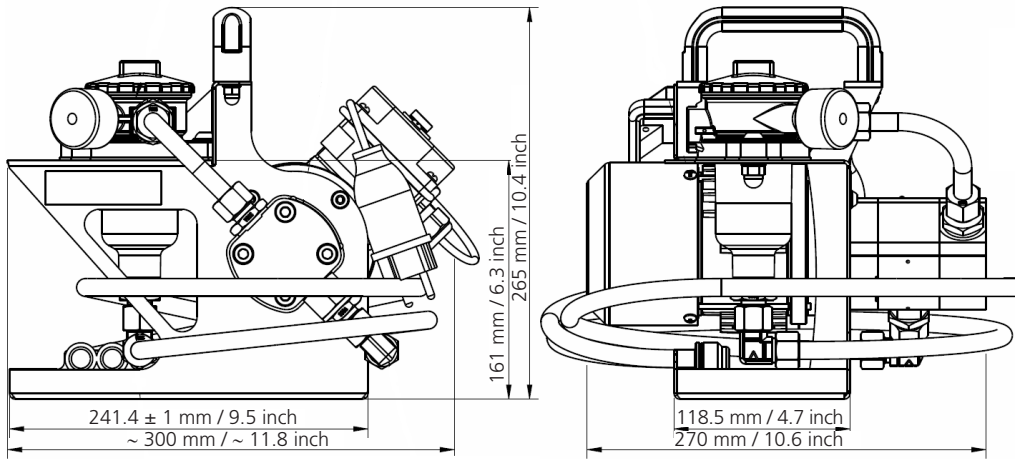

Basic device

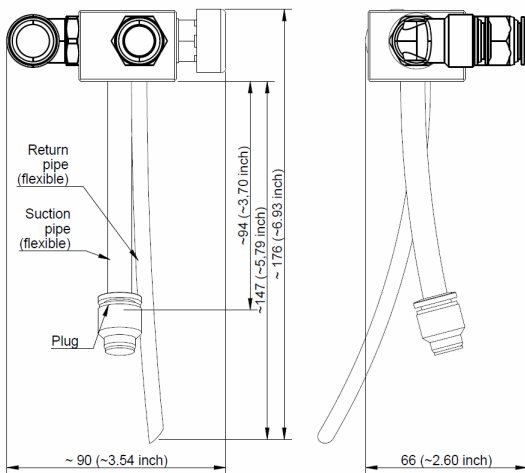

Suction-return adapter

Hydraulic Symbol

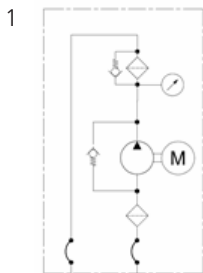

Quality Assurance

Quality management according to DIN EN ISO 9001

To ensure constant quality in production and operation, ARGO-HYTOS filter elements undergo strict controls and tests according to the following ISO standards:

- ISO 2941 Verification of collapse / burst pressure rating
- ISO 2942 Verification of fabrication integrity (Bubble Point Test)
- ISO 2943 Verification of material compatibility with fluids
- ISO 3968 Evaluation of pressure drop versus flow characteristics
- ISO 16889 Multi-Pass-Test (evaluation of filter fineness and dirt-holding capacity)
- ISO 23181 Determination of resistance to flow fatigue using high viscosity fluid

Various quality controls during the production process guarantee the leak-free function and solidity of our filters.

Illustrations may sometimes differ from the original. ARGO-HYTOS is not responsible for any unintentional mistake in this specification sheet.