

RFI Series

Reversible Flow Indicator

Reversible flow Indicators are designed for continuous monitoring or intermittent use commissioning and servicing hydraulic systems up to 420 bar, 6000 psi.

The large clear 63mm diameter dial ensures that quick checks can be made to determine pump performance and setting of flow control valves. They can be used on mobile and industrial hydraulic circuits. Also lubrication and coolant systems using oil.

These direct acting flow indicators can be installed in hazardous areas or on applications where no power is available. The flow indicator design ensures good reliability and minimises the effects of contamination.

Specifications

Maximum Rated Pressure:	Up to 420 bar, 6000 psi
Maximum Rated Flow:	Up to 200 L/min, 54 US gpm
Ambient Temperature:	-10 to 50°C, 14 to 122°F
Porting:	BSPP, SAE
Material:	Body Materials: Aluminium 2011T6
	Internal Materials: Stainless Steel, Brass
	Seals: NBR, FKM
Weight:	2.0 kg, 4.4 lb

Make it **BLUE**®

Features

- Accuracy within 4% FSD.
- Built-in thermometer.
- Allows reverse flow.
- Dual scale L/min/US gpm.
- Large clear dials.
- Horizontal or vertical mounting.
- Rugged design.
- Pressure gauge port.
- Wide operating range.

Symbol:

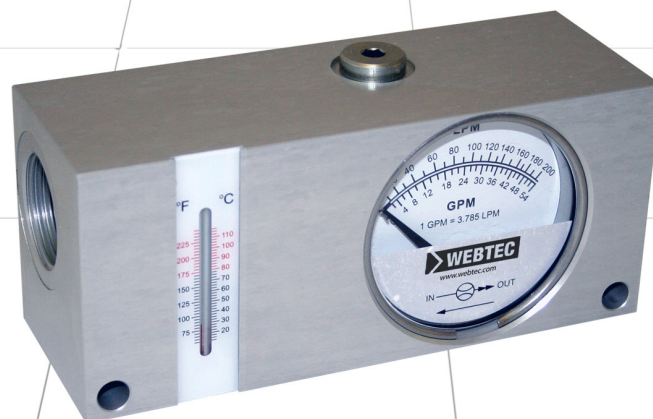
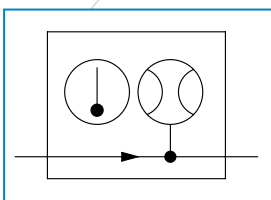

Sales Order Code

Please contact our technical sales to team to discuss any special order requirements.

MODEL NUMBER	CALIBRATED FLOW RANGE		MAIN PORTS	TOP PORTS
	L/MIN	US GPM		
RFI120-B-6	10 - 120	4 - 32	1" BSPP	1/4" BSPP
RFI120-S-6	10 - 120	4 - 32	1-5/16" -12UN #24 SAE ORB	1/4" NPTF
RFI200-B-6	10 - 200	4 - 54	1" BSPP	1/4" BSPP
RFI200-S-6	10 - 200	4 - 54	1-5/16" -12UN #24 SAE ORB	1/4" NPTF

Note - All NPTF threads are to ANSI B1.20.3 -1976 Class 1. As stated in the standard it is recommended that "sealing is accomplished by the means of a sealant applied to the thread". NPT fittings may also be used to connect to NPTF ports (also with a sealant applied to the thread).

Typical Pressure Drop Curves

All tests completed using ISO32 Mineral oil at 28 cSt

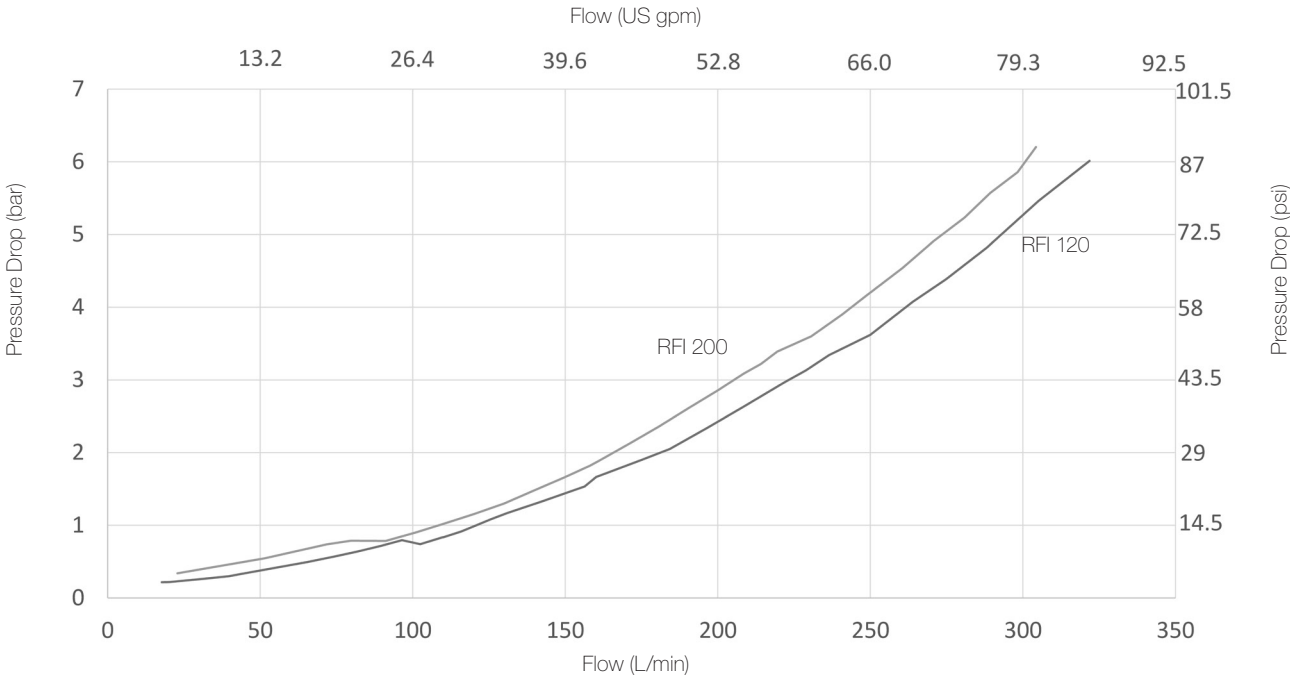

Installation Details

Dimensions in mm [Inches]

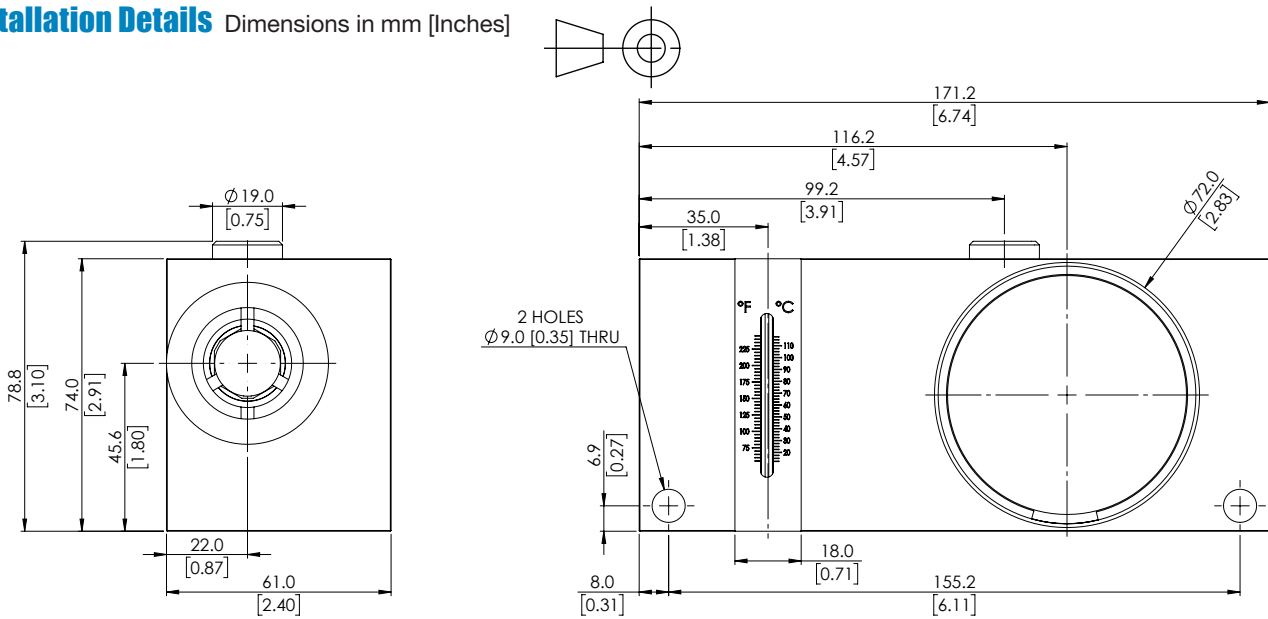

Functional Specification

Ambient Temperature Range:	-10 to 50°C, 14 to 122°F
Compatible Fluids:	Mineral oils to ISO 11158. Other fluids consult sales office.
Fluid Temperature Range:	20 to 80°C, 65 to 176°F continuous use. Intermittently (<10 minutes) up to 110°C, 230°F.
Accuracy:	
Flow:	± 4% of full scale
Temperature:	± 2.5°C (±5°F)

Operation

The flow indicator body houses a metering piston which moves against a calibrated spring. The piston is magnetically coupled to a rotary pointer to provide a direct reading of flow on the dial, flow scale is displayed in both L/min (LPM) and US gpm (GPM). The thermometer is also mounted in the body near the fluid flow. Both flow and temperature scales are shielded behind impact resistant windows.

Reverse Flow

The unit will allow reverse flow but will not measure the reverse flow, i.e. the flow needle will indicate zero.

Calibration

All Flow Indicators calibrated at a mean viscosity of 28cSt using ISO32 hydraulic mineral oil to ISO11158 category HM. Calibration certificates are available on request - this is a chargeable option. Other calibration on request - please consult sales office.

Installation

The unit can be installed in any position, horizontal, vertical or anywhere in between. The unit is designed to panel mount or pipe mount. When panel mounting ensure that rear and bottom faces of the unit are at least 12 mm (1/2") from any ferrous material such as an iron panel or base. The piston contains a magnet that can be affected by close proximity of ferrous material. The front face can be mounted directly to ferrous panels.

The indicator can be connected into pressure or return lines. All hydraulic connections should be made by suitably trained personnel.

Accessories

Pressure gauge fitted directly into block or remotely connected by micro bore hose, see pressure gauge bulletin.